

NOTES:

- BEFORE CONSTRUCTION OF ANY UTILITIES OR IMPROVEMENTS, THE CONTRACTOR SHALL NOTIFY THE DEPARTMENT OF PUBLIC WORKS (DPW), IN WRITING, OF INTENT TO PROCEED.
- ALL WATER MAINS, FITTINGS, APPURTENANCES AND OTHER MATERIALS, AND CONSTRUCTION SHALL CONFORM TO ALL APPLICABLE AWWA, STATE AND CITY CODES, STANDARDS AND REGULATIONS. IN THE CASE OF CONFLICT BETWEEN THESE CONSTRUCTION DETAILS AND SPECIFICATIONS AND A CODE OR REGULATION, THE DECISION OF THE VERMONT DEPARTMENT OF HEALTH OR VTDEC WATER SUPPLY SHALL BE BINDING.
- ALL WATER MAINS, FITTINGS, APPURTENANCES SHALL BE INSTALLED IN A WORKMANLIKE MANNER. INSTALLATION SHALL BE UNDER THE GENERAL INSPECTION OF THE PUBLIC WORKS DEPARTMENT. BEFORE ANY WATER LINE WORK IS COMMENCED BY THE CONTRACTOR, THEY SHALL NOTIFY THE PUBLIC WORKS DEPARTMENT AT LEAST FIVE (5) WORK DAYS IN ADVANCE OF HIS INTENTION TO PROCEED. ADDITIONAL NOTICE MAY BE REQUIRED DUE TO THE SIZE AND SCOPE OF THE WORK.
- CONNECTION TO AN EXISTING WATER MAIN SHALL BE DONE UNDER THE SUPERVISION OF, AND WITH THE APPROVAL OF THE PUBLIC WORKS DEPARTMENT. IT IS THE CONTRACTOR'S RESPONSIBILITY TO SECURE ALL NECESSARY PERMITS AND PERMISSION TO MAKE THE CONNECTION AND TO COORDINATE ALL PARTIES INVOLVED IN THE PROCESS. THE PUBLIC WORKS DEPARTMENT SHALL BE NOTIFIED AT LEAST FIVE (5) WORK DAYS IN ADVANCE OF THE INTENDED CONNECTION TIME. ADDITIONAL NOTICE MAY BE REQUIRED DUE TO THE SIZE AND SCOPE OF THE WORK.
- AN INSPECTOR EMPLOYED BY THE PUBLIC WORKS DEPARTMENT SHALL BE NOTIFIED AT LEAST TWO (2) DAYS IN ADVANCE OF ALL WATER LINE INSTALLATIONS. SAID INSPECTOR SHALL BE ON THE PREMISES FOR ALL WATER LINE INSTALLATIONS.
- AS-BUILTS PREPARED BY THE CONTRACTOR ARE REQUIRED BY THE PUBLIC WORKS DEPARTMENT AT THE TIME OF THE COMPLETION OF THE WATER SYSTEM. THE CONTRACTOR SHALL PROVIDE ACCURATE THE SHEETS FOR ALL NEW VALVES, FITTINGS AND CURB STOPS. THE CONTRACTOR SHALL ALLOW THE CITY TO ACCESS THE CONSTRUCTION SITE TO OBTAIN ADDITIONAL INFRASTRUCTURE INFORMATION THROUGHOUT THE PROJECT.
- ALL WATER MAINS SHALL HAVE HORIZONTAL AND VERTICAL DISTANCES AS DETAILED ON THIS DRAWING.
- ALL PUBLIC AND PRIVATE WATER MAINS: 1) 4" OR GREATER SHALL BE C-900 PIPE (PER NOTE 21 BELOW); 2) LESS THAN 4" IN DIAMETER SHALL BE ULTRA-HIGH WEIGHT, CTS POLYETHYLENE TUBING DESIGNED FOR A WORKING PRESSURE OF 200 PSI (AWWA C-901, ASTM-D-1248 AND ASTM-D-2737). ALL WATER LINE FITTINGS SHALL BE DUCTILE IRON, (AWWA C-110), CEMENT-LINED. FOR WATER LINES LESS THAN 4" IN DIAMETER, FITTINGS (OTHER THAN VALVES) SHALL MEET MANUFACTURER'S RECOMMENDATIONS AND MEET VERMONT ACT 193 REQUIREMENTS FOR LEAD CONTENT.
- ALL BURIED VALVES SHALL CONFORM TO AWWA C-509/C-515, AND BE RESILIENT WEDGE GATE VALVES UP TO 12 INCH IN SIZE, AND EITHER RESILIENT WEDGE OR BUTTERFLY VALVES FOR LARGER SIZES. STEM SHALL BE NON-RISING WITH 2 THRUST WASHERS. STEM SHALL HAVE DOUBLE O-RING SEALS. GATE SHALL BE CI RESILIENT WEDGE WITH SYNTHETIC ELASTOMER COATING AND SHALL BE FUSION BONDED EPOXY COATED INSIDE AND OUT. BONNET HARDWARE SHALL BE ASTM A307 CADMIUM PLATED. ALL BOLTS SHALL BE STAINLESS STEEL. ALL MAIN LINE VALVES SHALL OPEN RIGHT (CLOCKWISE) AND SHALL HAVE ADJUSTABLE IRON VALVE BOXES EXTENDING TO THE FINISHED GRADE (SEE TYPICAL DETAILS). ALL VALVES SHALL BE FURNISHED WITH POSI-CAP VALVE BOX ALIGNER DISKS INSTALLED OVER THE VALVE STEM AND UNDER THE OPERATING NUT. HYDRANTS SHALL BE IN ACCORD WITH AWWA C-502, 3-WAY POST TYPE BREAKAWAY KENNEDY K81AW COMPLETE INSERT HYDRANT, WITH TWO (2) 2-1/2" HOSE NOZZLES AND ONE (1) 4-1/2" STEAMER NOZZLE. NOZZLE THREADS SHALL BE ROXBURY DOUBLE-START. HYDRANTS SHALL BE PROVIDED WITH A 6.5" BURY (RISER). IN ALL CASES, IT IS THE CONTRACTOR'S RESPONSIBILITY TO CHECK WITH THE PUBLIC WORKS DEPARTMENT FOR ALL NEW VALVES, FITTINGS AND CURB STOPS. THE CONTRACTOR SHALL BE RESPONSIBLE FOR ALL SAMPLING AND ANALYSIS COSTS. TAP USED FOR CHLORINATION SHALL BE CLOSED AND PLUGGED PRIOR TO BACKFILL. THE CONTRACTOR SHALL PERFORM ALL CONSTRUCTION ACTIVITIES IN CONFORMANCE WITH THE LATEST EDITION OF AWWA C-651. THE CONTRACTOR SHALL RECEIVE THE LATEST EDITION OF BURLINGTON'S WATER REPAIR FLOW CHART TO ENSURE CONFORMANCE WITH AWWA C-651. THE CITY REQUIRES BAC-T SAMPLES BE COLLECTED AND TESTED ANY TIME THE EXISTING WATER SYSTEM IS CUT INTO.
- CURB BOXES SHALL BE BUFFALO TYPE WITH TELESCOPING TOP AND BOLT-ON CAPS.
- ALL WATER LINES AND APPURTENANCES SHALL BE PRESSURE AND LEAK-TESTED, BEFORE BEING PLACED INTO SERVICE. IN ALL CASES, IT IS THE CONTRACTOR'S RESPONSIBILITY TO CHECK WITH THE PUBLIC WORKS DEPARTMENT FOR ALL NEW VALVES, FITTINGS AND CURB STOPS. THE TEST PRESSURE SHALL BE 200 PSI (1 1/2" SP3), MEASURED AT OR NEAR THE HIGH POINT IN THE PORTION OF THE SYSTEM BEING TESTED, AND THE TEST SHALL BE RUN FOR TWO (2) HOURS. THE PUBLIC WORKS DEPARTMENT SHALL BE GIVEN AT LEAST TWENTY-FOUR (24) HOURS NOTICE BEFORE THE TEST IS TO BE CONDUCTED, AND DPW PERSONNEL SHALL WITNESS THE TEST. ALLOWABLE LEAKAGE SHALL BE COMPUTED BY THE FOLLOWING FORMULA, $L = (S \times D \times \text{SQ. ROOT}(P)) / 133200$, WHERE L=NUMBER OF GALLONS ALLOWED LEAKAGE PER HOUR, S=LENGTH OF PIPE TESTED IN FEET, D=INCHES OF NOMINAL PIPE DIAMETER, P=AVERAGE TEST PRESSURE (PSI GAUGE). THE PERSON(S) CONDUCTING THE TEST(S) SHALL, IN WRITING, CERTIFY THE RESULTS TO THE PUBLIC WORKS DEPARTMENT.
- ALL WATER LINES, BEFORE BEING PUT INTO SERVICE, SHALL BE DISINFECTED IN ACCORDANCE WITH THE LATEST EDITION OF AWWA C-651, OR AS DIRECTED BY THE PUBLIC WORKS DEPARTMENT. CONTRACTOR SHALL INSTALL A TAP IN WATER MAIN FOR CHLORINE INJECTION. TAP SHALL BE LOCATED AS APPROVED BY THE PUBLIC WORKS DEPARTMENT. THE PERSON(S) RESPONSIBLE FOR DISINFECTION SHALL CERTIFY, IN WRITING, TO THE PUBLIC WORKS DEPARTMENT AND VERMONT DEPARTMENT OF HEALTH THAT THIS DISINFECTION PROCEDURE WAS FOLLOWED AND THE REQUIRED MINIMUM RESULTS WERE OBTAINED. CONTRACTOR SHALL BE RESPONSIBLE FOR ALL SAMPLING AND ANALYSIS COSTS. TAP USED FOR CHLORINATION SHALL BE CLOSED AND PLUGGED PRIOR TO BACKFILL. THE CONTRACTOR SHALL PERFORM ALL CONSTRUCTION ACTIVITIES IN CONFORMANCE WITH THE LATEST EDITION OF AWWA C-651. THE CONTRACTOR SHALL RECEIVE THE LATEST EDITION OF BURLINGTON'S WATER REPAIR FLOW CHART TO ENSURE CONFORMANCE WITH AWWA C-651. THE CITY REQUIRES BAC-T SAMPLES BE COLLECTED AND TESTED ANY TIME THE EXISTING WATER SYSTEM IS CUT INTO.
- WATER MAIN VALVES AND CURB STOPS SHALL BE INSIDE CITY RIGHT-OF-WAY.
- VALVES, HYDRANTS, CURB STOPS, ETC. SHALL BE OPERATED ONLY BY THE PUBLIC WORKS DEPARTMENT.
- ALL TAPS LARGER THAN 1" REQUIRE THE USE OF BRONZE SADDLES. SADDLES ARE REQUIRED FOR ALL TAPS ON PVC PIPE AND SADDLES SHALL BE APPROVED FOR USE ON C900 PVC PIPE.
- ALL BRASS UNIONS AND ADAPTERS SHALL BE LOW-LEAD BY CAMBRIDGE.
- ALL CORPORATIONS AND CURB STOPS SHALL BE CAMBRIDGE WITH NITRILE GASKETS.
- WATER MAINS 4" AND LARGER SHALL BE AWWA C900 PVC PIPE WITH A PRESSURE CLASS OF 305 PSI (DR14) MAINS 2" OR LESS SHALL CONFORM TO AWWA C901 AND BE HOPE CTS SOLID BLUE PIPE WITH A PRESSURE CLASS OF 200 PSI (SDR 9). ALL PLASTIC PIPE (INCLUDING SERVICES) WILL REQUIRE A 12 AWG HIGH STRENGTH COPPER CLAD STEEL TRACER WIRE WITH BLUE INSULATION FASTENED DIRECTLY TO THE TOP OF PIPE WITH NYLON TIE WRAPS OR ELECTRICAL TAPE. THIS TRACER WIRE SHALL BE A CONTINUOUS RUN (NO SPLICES) BETWEEN VALVES WITH ENDS FOR ATTACHING A LOCATING SIGNAL AT EVERY VALVE BOX, END OF PIPE RUN OR EVERY 500' OF PIPE, WHICHEVER IS LESS. IF NO VALVE BOXES ARE LOCATED WITHIN 500' OF EACH OTHER, A MAGNETIZED TRACER BOX IS REQUIRED. WATERPROOF SPLICES SHALL BE ALLOWED IN VALVE BOXES TO MEET THE DETAIL ON THIS SHEET. TRACER WIRE, TRACER BOXES AND WIRE NUTS SHALL BE MANUFACTURED BY COPPERHEAD INDUSTRIES OR APPROVED EQUAL. IN ADDITION, DETECTABLE METALLIC UNDERGROUND TAPE LABELED "CAUTION BURIED WATER LINE BELOW" SHALL BE MANUFACTURED BY TRUMBULL INDUSTRIES OR APPROVED EQUAL AND BURIED APPROX. 2" BELOW FINISHED GRADE.
- NITRILE BUTADIENE RUBBER (NBR) GASKETS SHALL BE USED IN LIEU OF THE STANDARD STYRENE BUTADIENE RUBBER (SBR) GASKETS FOR C900 WATER PIPE AND FITTINGS.

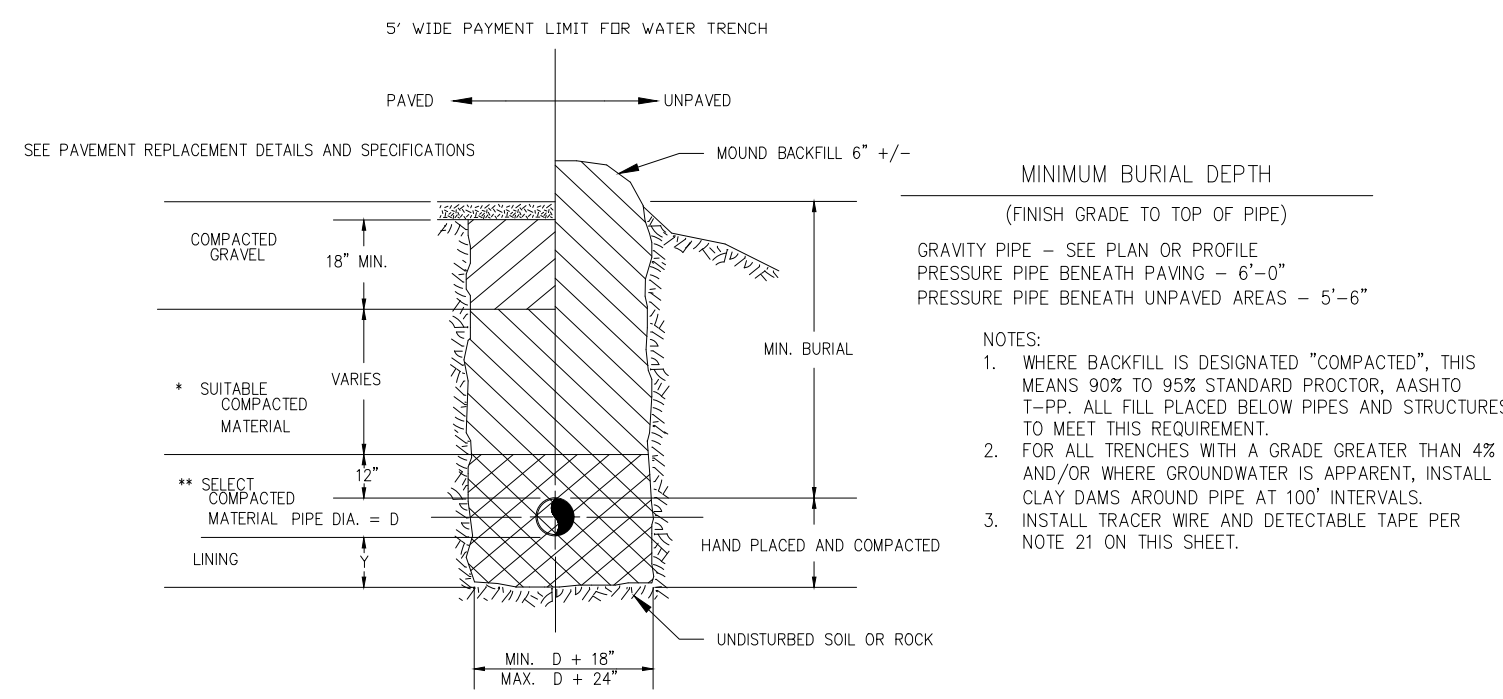

Y - DIMENSION	CONDITION & PIPE	** SELECT MATERIAL	LINING
0"	DUCTILE IRON PIPE IN "ORDINARY SOIL"	TYPE I II OR III	-
6"	ALL PIPE OVER BEDROCK OR LEDGE	TYPE II OR III	SAND OR TYPE III
4"	DUCTILE IRON PIPE IN CLAY OR MUCK	TYPE II OR III	SAND
6"	PLASTIC - ALL	SAND	SAND

- SUITABLE MATERIAL SHALL CONTAIN NO STONES GREATER THAN 4" IN DIAMETER, NO FROZEN LUMPS, AND ONLY MINOR AMOUNTS OF CLAY OR ORGANIC MATERIAL. ALL MATERIAL TO BE PLACED IN MAXIMUM OF 12" LIFTS AND COMPACTED BEFORE PLACING NEXT LIFT.
- TYPE I MATERIAL SHALL BE EITHER GRAVEL OR EXCAVATED MATERIAL CONTAINING NO STONES GREATER THAN 1-1/2" IN DIAMETER, NO FROZEN MATERIAL, NO CLAY, AND NO ORGANIC MATERIAL.
- TYPE II MATERIAL SHALL BE CLEAN, HARD, CRUSHED OR NATURAL STONE WITH A GRADATION BY WEIGHT OF 100% PASSING A 1-1/2" SQUARE OPENING, NOT MORE THAN 25% PASSING A 3/4" SQUARE OPENING, AND NOT MORE THAN 5% PASSING A 1/2" SQUARE OPENING.
- TYPE III MATERIAL SHALL BE CLEAN, HARD, CRUSHED STONE FREE FROM COATINGS AND THOROUGHLY WASHED WITH A GRADATION BY WEIGHT OF 100% PASSING A 1" SQUARE OPENING AND 0% TO 5% PASSING THROUGH A 1/4" SQUARE OPENING.

TYPICAL TRENCH DETAIL
N.T.S.

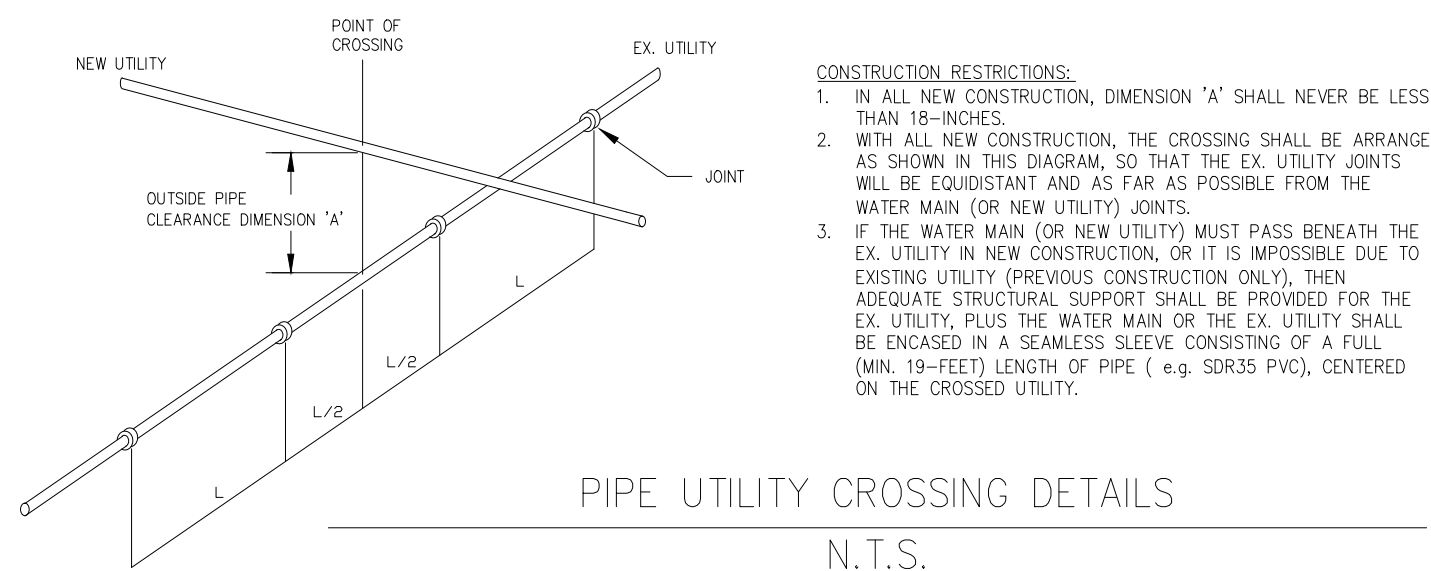

PIPE UTILITY CROSSING DETAILS
N.T.S.

- CONSTRUCTION RESTRICTIONS:
- IN ALL NEW CONSTRUCTION, DIMENSION 'A' SHALL NEVER BE LESS THAN 18-INCHES.
 - WITH ALL NEW CONSTRUCTION, THE CROSSING SHALL BE ARRANGE AS SHOWN IN THIS DIAGRAM, SO THAT THE EX. UTILITY JOINTS WILL BE EQUIDISTANT AND AS FAR AS POSSIBLE FROM THE WATER MAIN (OR NEW UTILITY) JOINTS.
 - IF THE WATER MAIN (OR NEW UTILITY) MUST PASS BENEATH THE EX. UTILITY IN NEW CONSTRUCTION, OR IT IS IMPOSSIBLE DUE TO EXISTING UTILITY (PREVIOUS CONSTRUCTION ONLY), THEN ADEQUATE STRUCTURAL SUPPORT SHALL BE PROVIDED FOR THE EX. UTILITY, PLUS THE WATER MAIN OR THE EX. UTILITY SHALL BE ENCASED IN A SEAMLESS SLEEVE CONSISTING OF A FULL (MIN. 19-FEET) LENGTH OF PIPE (e.g. SDR35 PVC), CENTERED ON THE CROSSED UTILITY.

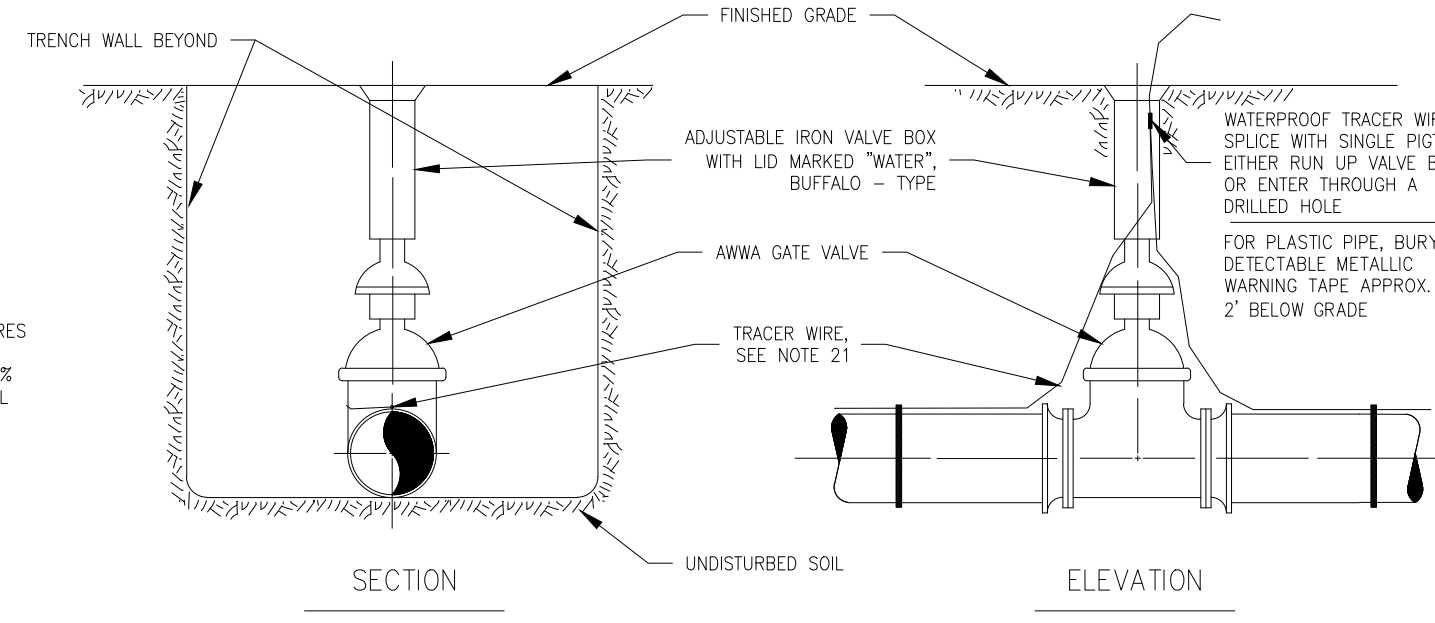

BURIED GATE VALVE DETAIL
N.T.S.

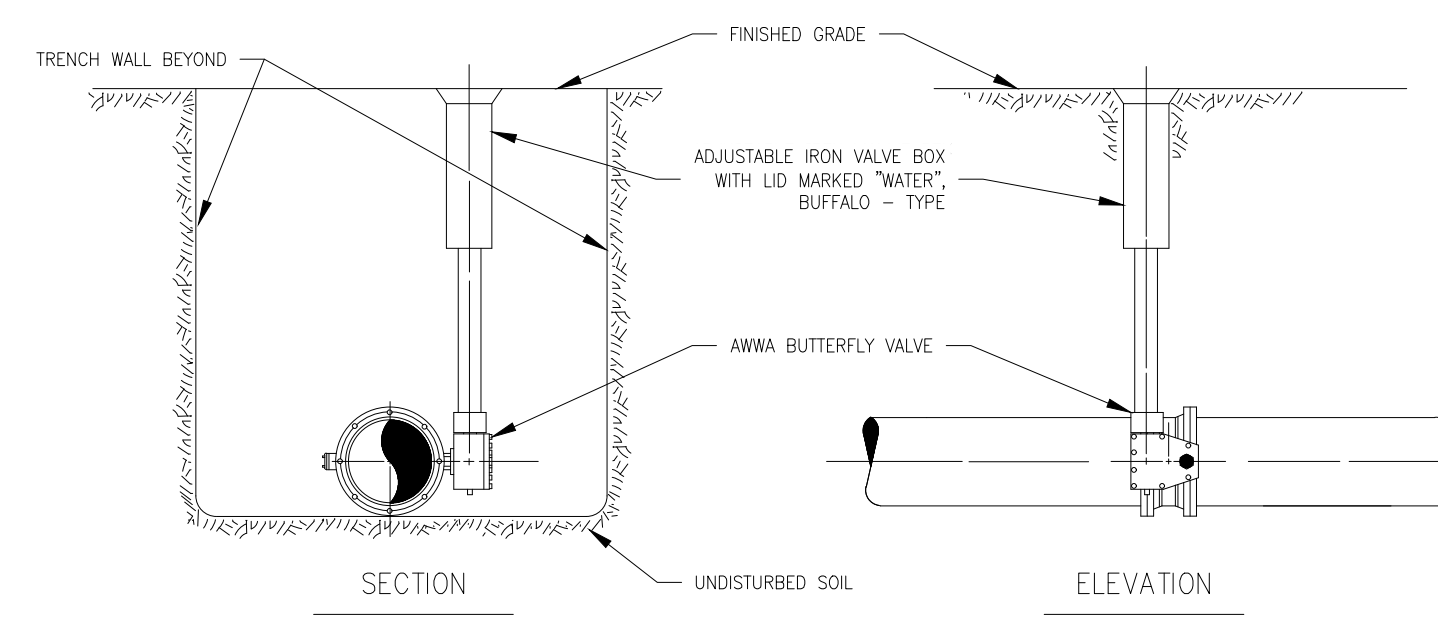

BURIED BUTTERFLY VALVE DETAIL
N.T.S.

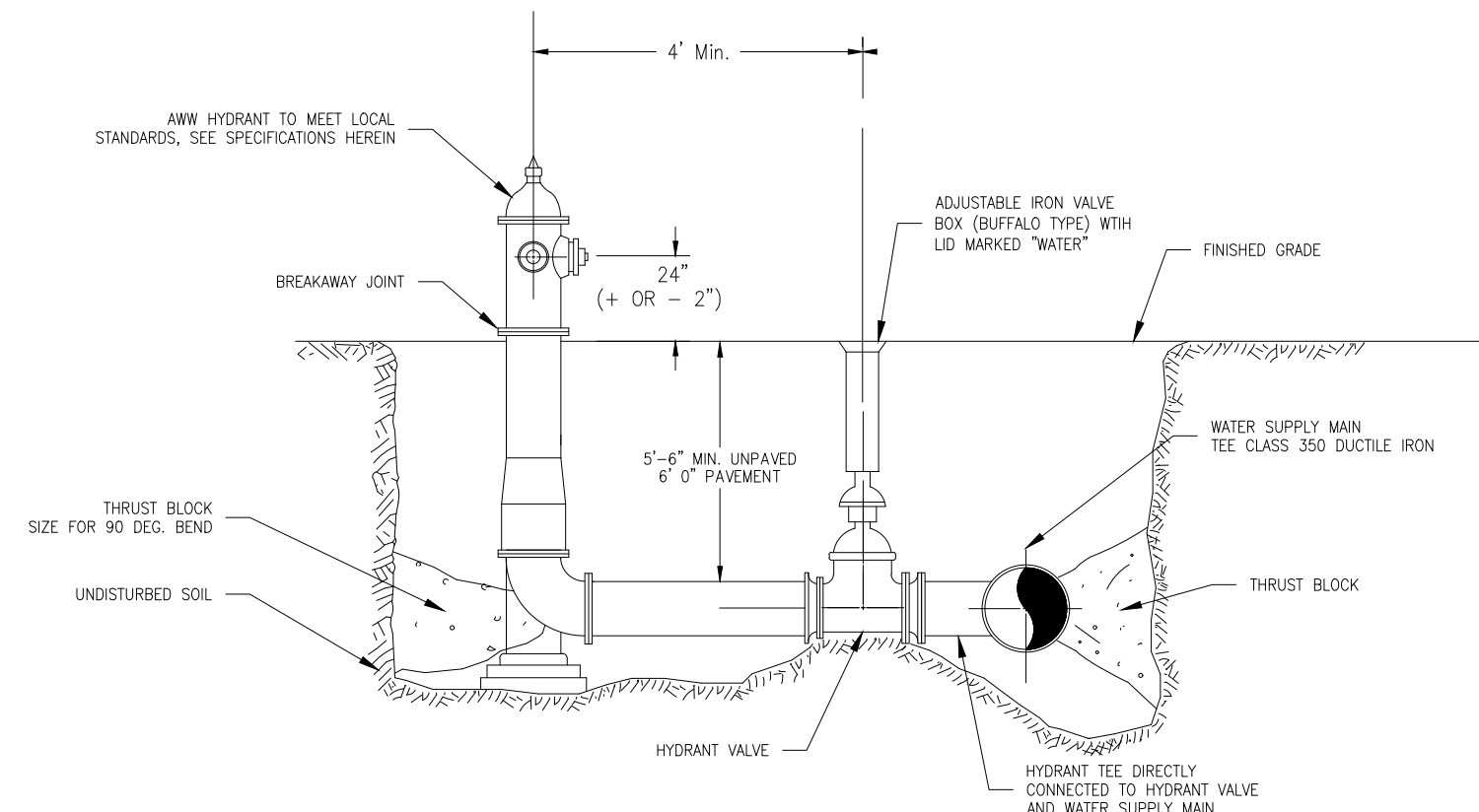

- NOTES:
- ALL HYDRANT DRAINS MUST BE PLUGGED, SEE NOTES.
 - ALL FITTINGS BETWEEN HYDRANT TEE AND HYDRANT SHALL BE RESTRAINED FITTINGS.
 - USE MEGALUG RETAINER GLANDS FOR ALL CONNECTIONS.

TYPICAL HYDRANT INSTALLATION
N.T.S.

BURLINGTON, VT COMPLETE INSERT FIRE HYDRANT SPECIFICATIONS:

- KENNEDY VALVE ITEM #154686553510BYVT (HYD 5" K81AW, PVC FROST JKT, 6).
- UPPER: 5-1/4" K81AW-BL 3-W AWWA
- COLOR: RED (01)
- HOSE: 2-1/2" - 3.058 X 3 DOUBLE TPI 1/6 PITCH - 1/3 LEAD
- STEAMER: 4" - 5.250" OD X 4 TPI
- NUT SIZE: 1-1/2" P W/AW DIRT SHIELD
- OPEN: LEFT
- TRENCH: 6"-6" WITH PROTECTIVE CASE CAP & FROST JACKET
- ELBOW: M62 6" MJ - EPOXY
- STENCIL: "BURLINGTON, VT"

- NOTES:
- HYDRANTS SHALL BE GUARDIAN K-81AW AS MANUFACTURED BY KENNEDY VALVE.
 - FIRE HYDRANT MUST HAVE A NO DRAIN SEAT RING
 - HYDRANTS SHALL BE "COMPLETE INSERT TYPE" WITH THE LOWER BARREL THREADED INTO THE ELBOW. DESIGNS USING FASTENERS TO SECURE THE LOWER BARREL TO THE LOWER BARREL AND ELBOW SHALL BE DUCTILE IRON. CAST IRON WILL NOT BE ACCEPTED.
 - THE ELBOW SHALL BE EPOXY COATED AND UTILIZE BRASS TUBE DRAIN HOLES. A BRASS SEAT RING INSERT SHALL BE THREADED INTO THE ELBOW AND MECHANICALLY RETAINED BY TWO BRASS SET SCREWS.
 - THE PROTECTIVE CASE SHALL BE C909 PIPE.
 - THE CASE CAP SHALL BE POLYESTER COATED IRON.
 - THE HYDRANT SHALL BE FULLY MAINTAINABLE THROUGH THE UNITIZED ONE PIECE DESIGNED BONNET.
 - THE OPERATING NUT SHALL BE OF ONE PIECE BRONZE CONSTRUCTION INCORPORATING AN IRON DIRT SHIELD.
 - NOZZLES SHALL BE TAMPER RESISTANT 1/4 TURN TYPE WITH O-RINGS AND STAINLESS STEEL RETAINING SCREWS.
 - THE MAIN VALVE SHALL BE SYNTHETIC RUBBER REINFORCED WITH STEEL.

FIRE HYDRANT DETAILS & SPECIFICATIONS
N.T.S.

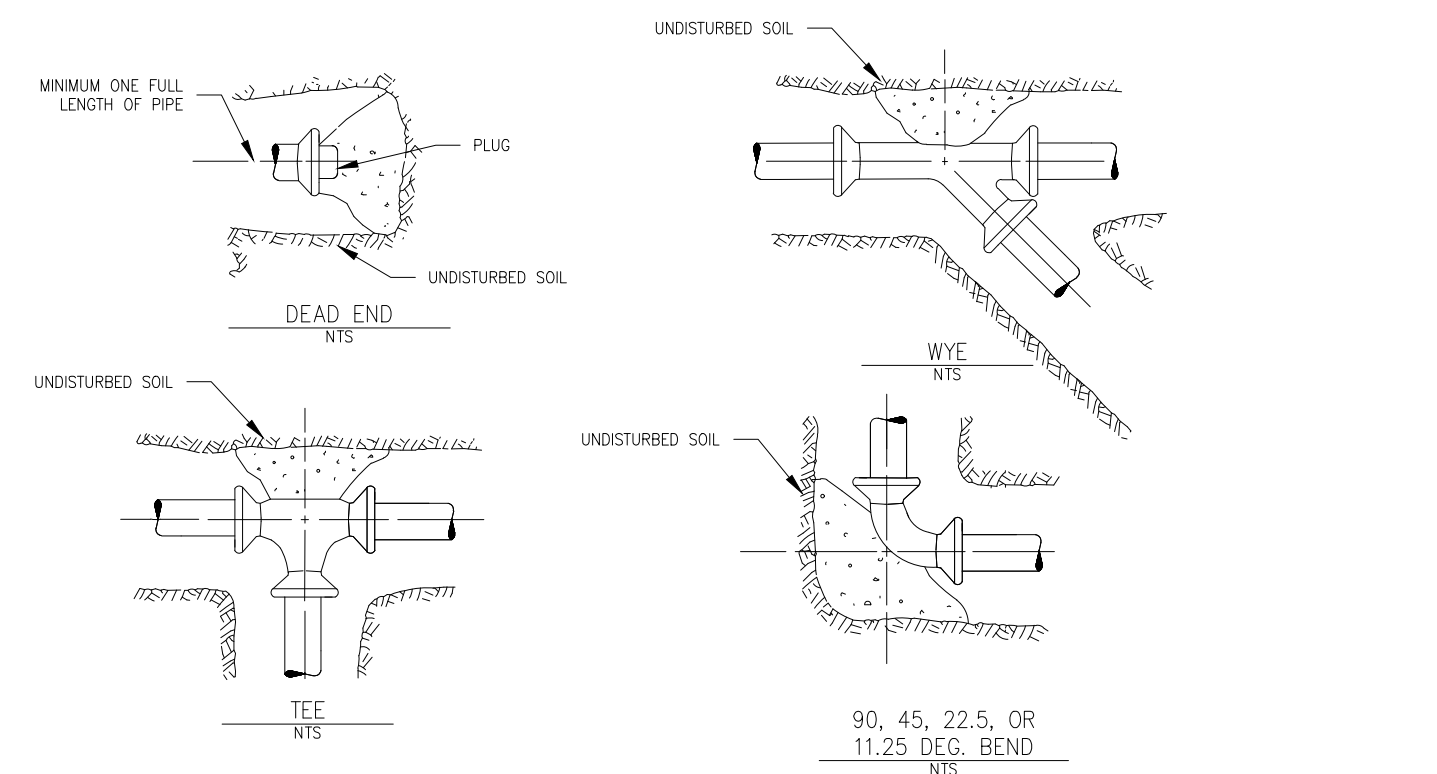

MINIMUM AREA OF BEARING SURFACE OF CONC. THRUST BLOCKS (IN SQUARE FEET)

3"			4"			6"			8"			12"			SOIL CONDITION	SAFE BEARING CAPACITY (PSF)
ENDS TIES	HP ELB.	HP TEE	ENDS TIES	HP ELB.	HP TEE	ENDS TIES	HP ELB.	HP TEE	ENDS TIES	HP ELB.	HP TEE	ENDS TIES	HP ELB.	HP TEE		
0.5	0.5	0.5	0.5	0.5	0.5	1.0	1.5	1.0	2.0	2.5	1.5	4.0	5.5	3.0	1.5	4,000
1.0	1.0	1.0	1.5	2.0	1.5	3.0	4.0	2.0	4.5	6.5	3.5	10.0	14.0	7.5	4.0	CEMENTER GRAVEL & SAND
1.0	1.5	1.0	0.5	2.0	2.5	1.0	3.5	5.0	3.0	6.5	5.0	2.5	13.0	18.5	10.0	COARSE & FINE COMPACT SAND
1.5	2.5	1.5	1.0	2.5	3.5	2.0	5.5	7.5	4.0	9.0	13.0	7.0	3.5	20.0	27.5	MEDIUM CLAY (CAN BE SPREAD)
3.0	4.5	2.5	1.5	5.0	7.0	4.0	2.0	10.5	15.0	8.0	4.0	18.0	25.0	14.0	7.0	SOFT CLAY

MAXIMUM WATER PRESSURE = 300 PSI NOTE: REDUCER BEARING AREA = 45 DEG. BEND, LARGER PIPE

THRUST BLOCK DETAILS
N.T.S.

THE STANDARDS ARE TO BE USED BY ENGINEERING PROFESSIONALS FOR PROJECTS WITHIN THE CITY. THE STANDARD DETAILS MAY NEED TO BE MODIFIED WITH CITY APPROVAL TO MEET PROJECT SPECIFIC APPLICATIONS. THE STANDARDS DO NOT COVER ALL ASPECTS OF WATER RESOURCES INFRASTRUCTURE AND IT IS THE RESPONSIBILITY OF THE DESIGNER TO ENSURE CONSTRUCTION DETAILS ARE COMPLETE FOR SPECIFIC APPLICATIONS. THE CITY IS NOT RESPONSIBLE FOR THE USE OF THESE STANDARDS FOR APPLICATIONS THAT ARE NOT APPROPRIATE. THE STANDARD DETAILS WILL BE PERIODICALLY UPDATED. IT IS THE RESPONSIBILITY OF THE DESIGNER TO CONFIRM THE STANDARDS THEY ARE USING ARE THE MOST RECENT VERSIONS.

1	REV A - INITIAL RELEASE	OCT 2023
---	-------------------------	----------

BURLINGTON PUBLIC WORKS Water Resources
53 LAVALLEY LANE
BURLINGTON, VT 05401
(802) 863-4501
WATER-RESOURCES@BURLINGTONVT.GOV

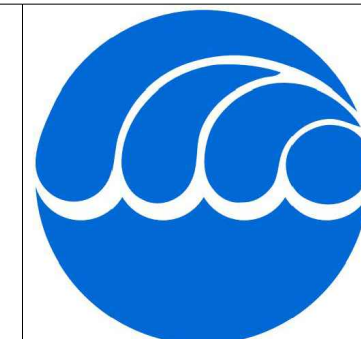

TYPICAL WATER SYSTEM DETAILS I

DESIGNED AEW	RFS NO.
DRAWN AEW	SCALE NTS
CHECKED	DRAWING NO.
DATE OCTOBER 2023	SHEET 2 OF 1